

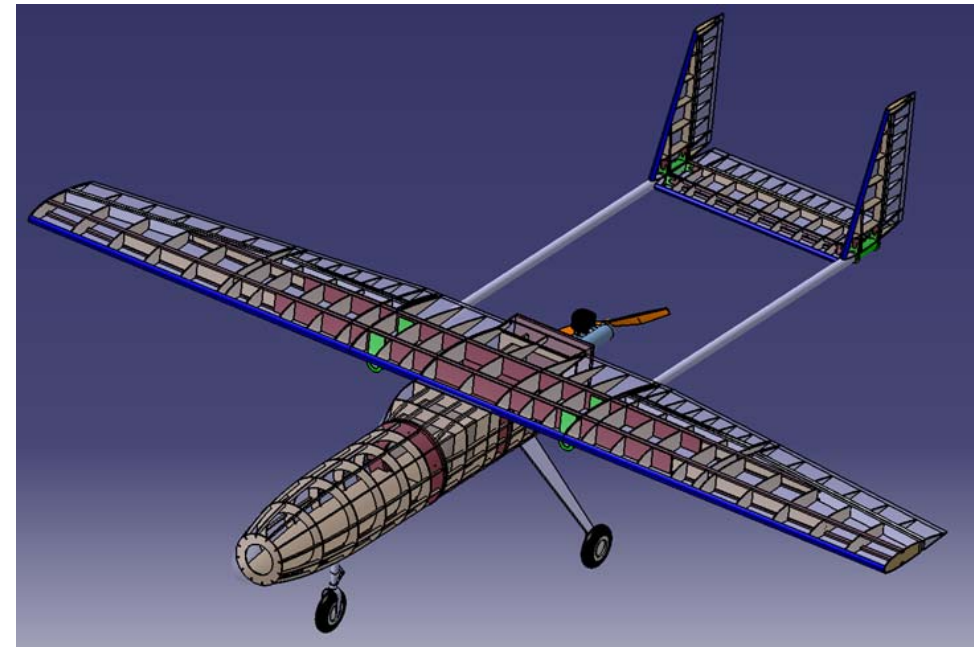

- Datos geométricos Céfiro:
  - Superficie alar –  $S = 1,088 \text{ m}^2$
  - Superficie cola horizontal-  $S_t = 0,176 \text{ m}^2$
  - Superficie cola vertical-  $S_t = 0,176 \text{ m}^2$
  - Cuerda media del ala –  $c = 0,39299 \text{ m}$
  - Cuerda encastre –  $c_r = 0,459 \text{ m}$
  - Cuerda encastre –  $c_t = 0,308 \text{ m}$
  - "Aspect ratio" -  $AR = 7,27$
  - Envergadura del ala -  $b = 2,81 \text{ m}$
  - Fuselaje –  $1,51 \text{ m}$
- Peso en vacío:  $15 \text{ kg}$  (con motor)





## ■ Balsa

### ■ Hojas

- $1/8 \times 4 \times 36''$  - 3,175 mm – 0,1371 grs/cm<sup>3</sup> : costillas ala, estabilizador horizontal y vertical, cuadernas fuselaje, recubrimiento.
- $1/4 \times 4 \times 36''$  - 6,35 mm – 0,1288 grs/cm<sup>3</sup> : suelo y paredes sin carga de pago.
- $3/8 \times 3 \times 36''$  - 9,525 mm – 0,0928 grs/cm<sup>3</sup> : largueros.

### ■ Tiras de balsa: $1/8 \times 3/8 \times 36''$ 0,2117 grs/cm<sup>3</sup> : larguerillos

### ■ Borde de ataque: alas, estabilizador horizontal y vertical

- $1 \times 36''$  - 25,4 mm – 0,1350 grs/cm<sup>3</sup>
- $3/4 \times 36''$  - 19,05 mm – 0,1299 grs/cm<sup>3</sup>

### ■ Borde de salida triangular: sección final ala y estabilizadores

- $1 \times 1 \times 36''$  - 25,4 mm – 0,1110 grs/cm<sup>3</sup>
- $3/4 \times 3/4 \times 36''$  - 19,05 mm – 0,1306 grs/cm<sup>3</sup>

### ■ Borde de salida triangular: sección final superficies de control

- $3/8 \times 1 - 1/2 \times 36''$  - 9,525 mm – 0,1868 grs/cm<sup>3</sup>
- $5/16 \times 1 - 1/4 \times 36''$  - 7,9375 mm – 0,2170 grs/cm<sup>3</sup>

### ■ Bloques de balsa: $2 \times 3 \times 36''$ – 0,0883 grs/cm<sup>3</sup> : carenados, wingtip

### ■ Contrachapado

- $1/8 \times 1/2 \times 36''$  - 6,35 mm – 0,6174 grs/cm<sup>3</sup> : costillas, cuadernas, largueros maestros, y suelo para soportar carga de pago.
- $3/8 \times 1/2 \times 24''$  - 9,525 mm – 0,6362 grs/cm<sup>3</sup> : cortafuegos motor

## ■ Madera solida:

- Pino - 0,600 grs/m<sup>3</sup>
- Spruce (abeto) -  $1/4 \times 1/2 \times 36''$  - 6,35 mm – 0,5642 grs/cm<sup>3</sup> : soporte largueros

# Maderas en Céfiro - II



	grosor (mm)	ancho (mm)	largo (mm)	volumen (cm <sup>3</sup> )	peso unidad (grs)	densidad (grs/cm <sup>3</sup> )
Balsa sheets 1/8 x 4 x 36"	3,175	101,6	914,4	294,97	40,44	0,1371
Balsa sheets - 1/4 x 4 x 36	6,35	101,6	914,4	589,93	76,00	0,1288
Balsa strips - 1/8 x 3/8 x 36"	3,175	9,525	914,4	27,65	5,85	0,2117
Balsa sheets - 3/8 x 3 x 36"	9,525	76,2	914,4	663,68	61,57	0,0928
Balsa trailing edge triangular - 1 x 1 x 36"	25,4	25,4	914,4	294,97	32,75	0,1110
Balsa trailing edge triangular - 3/4 x 3/4 x 36"	19,05	19,05	914,4	165,92	21,67	0,1306
Balsa trailing edge - 3/8 x 1-1/2 x 36"	9,525	38,1	914,4	165,92	31,00	0,1868
Balsa trailing edge - 5/16 x 1-1/4 x 36"	7,9375	31,75	914,4	115,22	25,00	0,2170
Balsa leading edge - 1 x 36"	25,4	19,05	914,4	442,45	59,75	0,1350
Balsa leading edge - 3/4 x 36"	19,05	14,2875	914,4	248,88	32,33	0,1299
Balsa block - 2 x 3 x 36"	50,8	76,2	914,4	3539,60	312,50	0,0883
Spruce Spruce strip - 1/4 x 1/2 x 36"	6,35	12,7	914,4	73,74	41,61	0,5642
Plywood Sheeting - 1/8 x 12 x 24"	3,175	304,8	609,6	589,93	370,67	0,6283
Plywood Sheeting - 1/8 x 12 x 36"	3,175	304,8	914,4	884,90	539,00	0,6091
Plywood Sheeting - 1/8 x 24 x 48"	3,175	609,6	1219,2	2359,74	1451,00	0,6149
Plywood Sheeting - 3/8 x 12 x 24"	9,525	304,8	609,6	1769,80	1126,00	0,6362

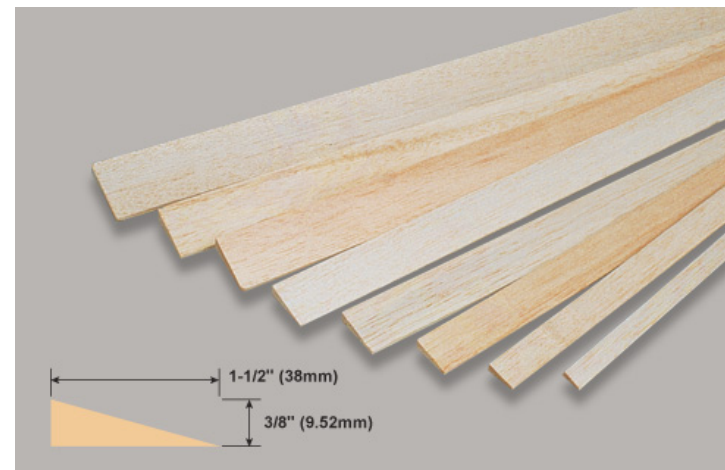
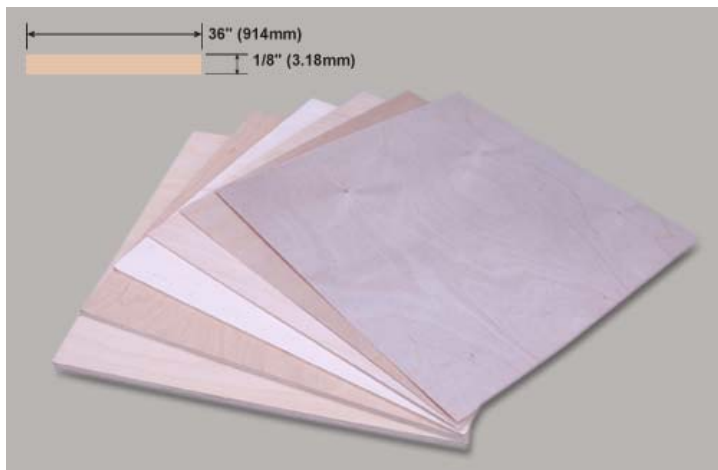
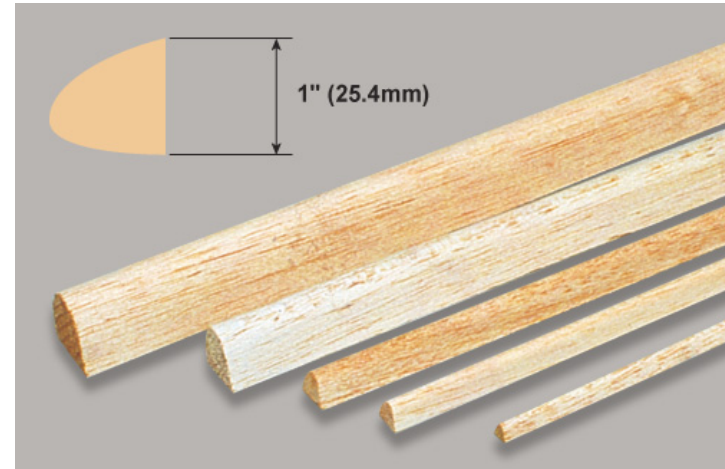
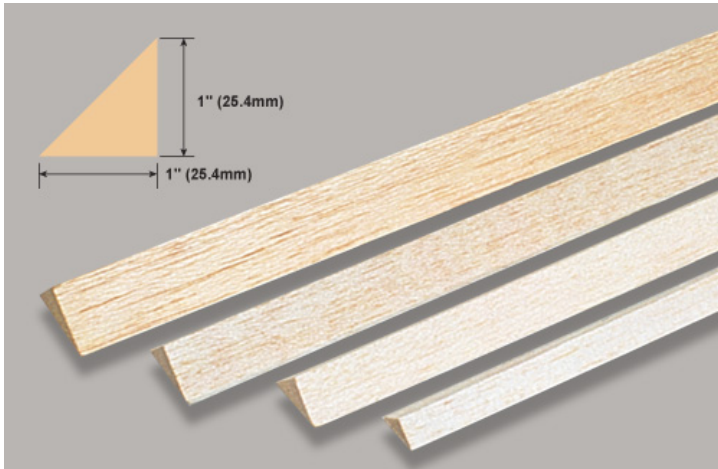
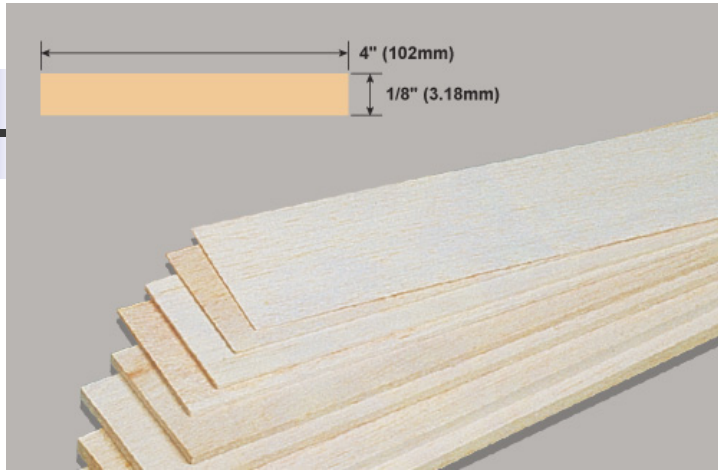
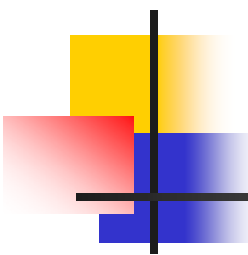

# Maderas en Céfiro - III

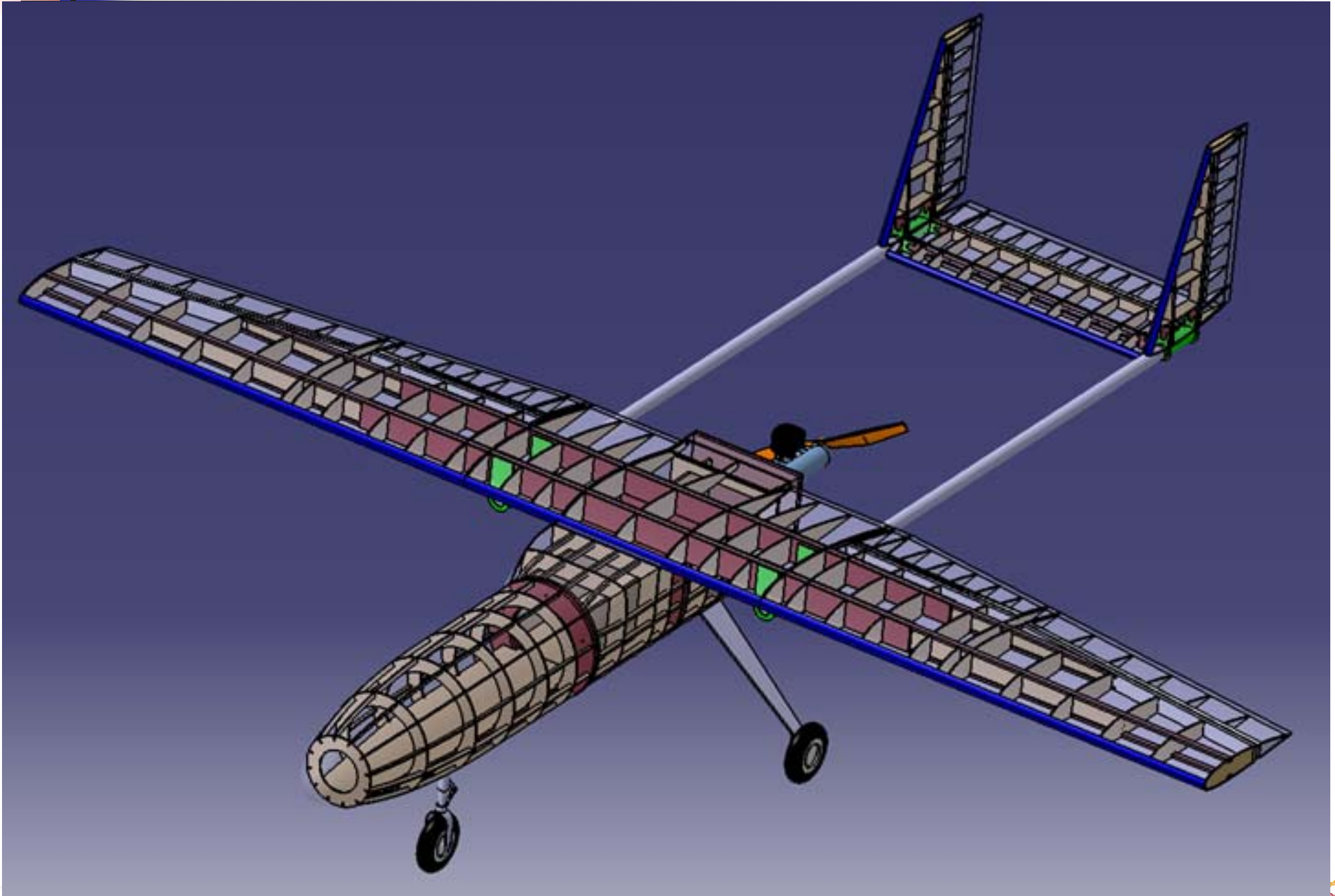

# Maderas en Céfiro - IV

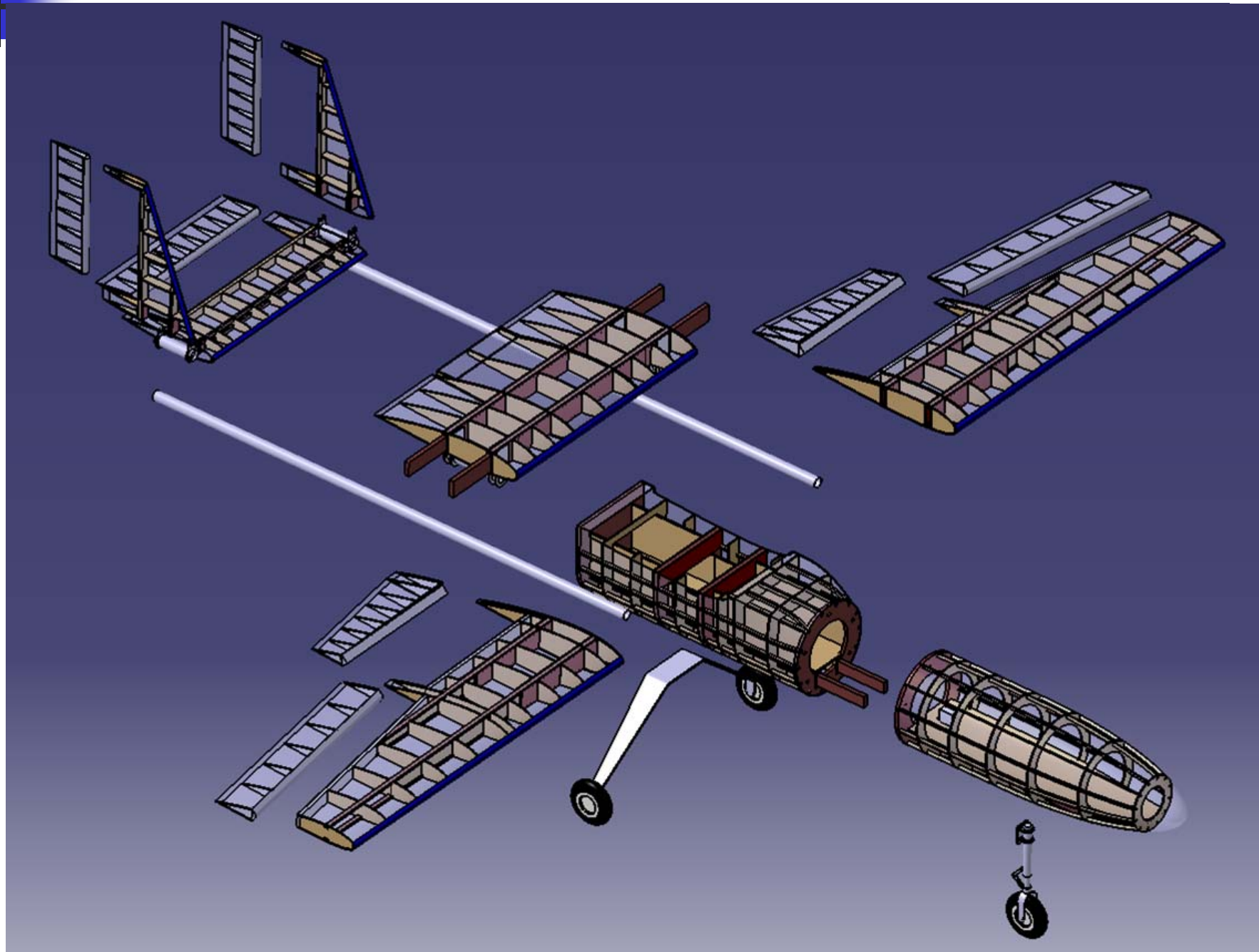

# Maderas en Céfiro - V

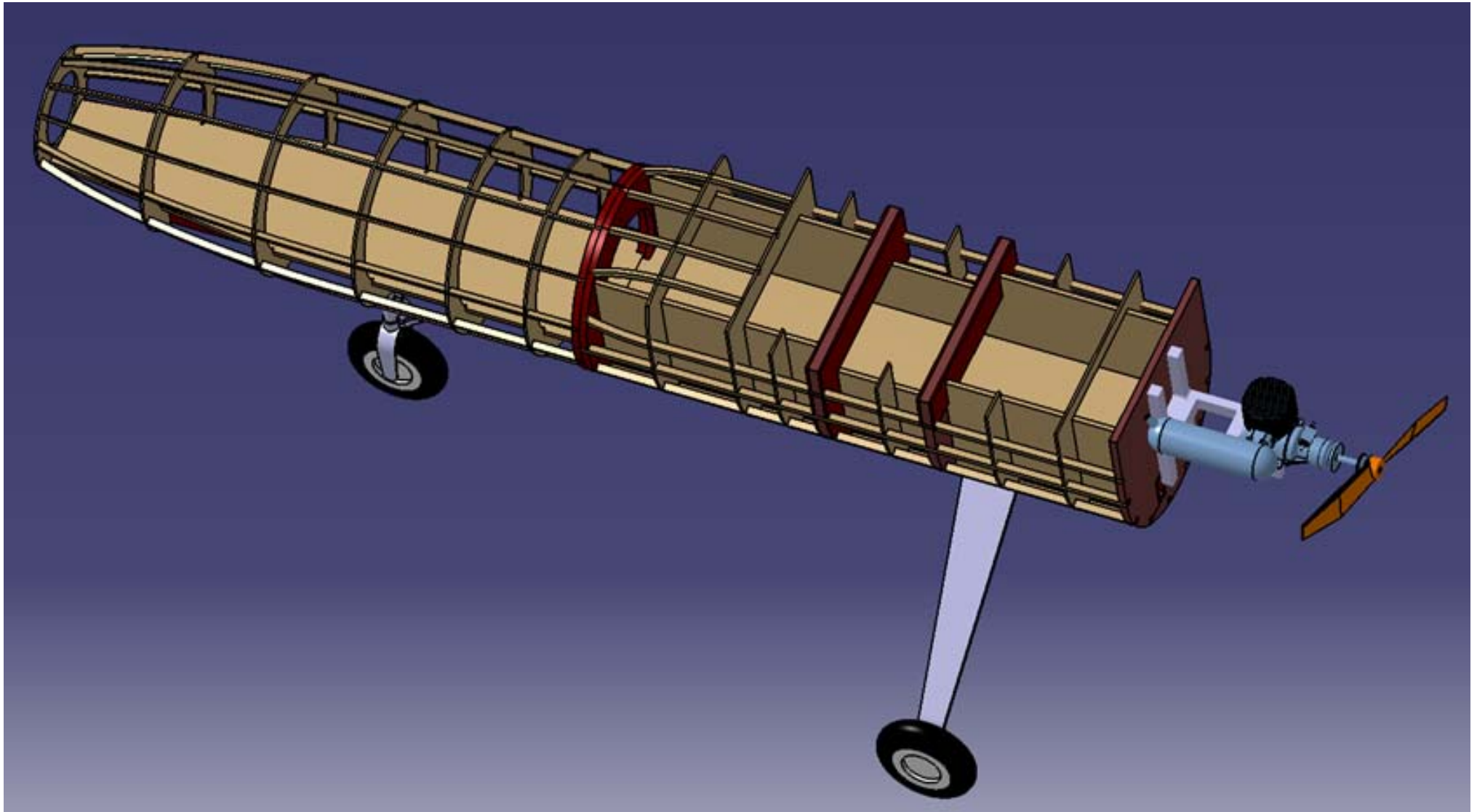

# Maderas en Céfiro - VI

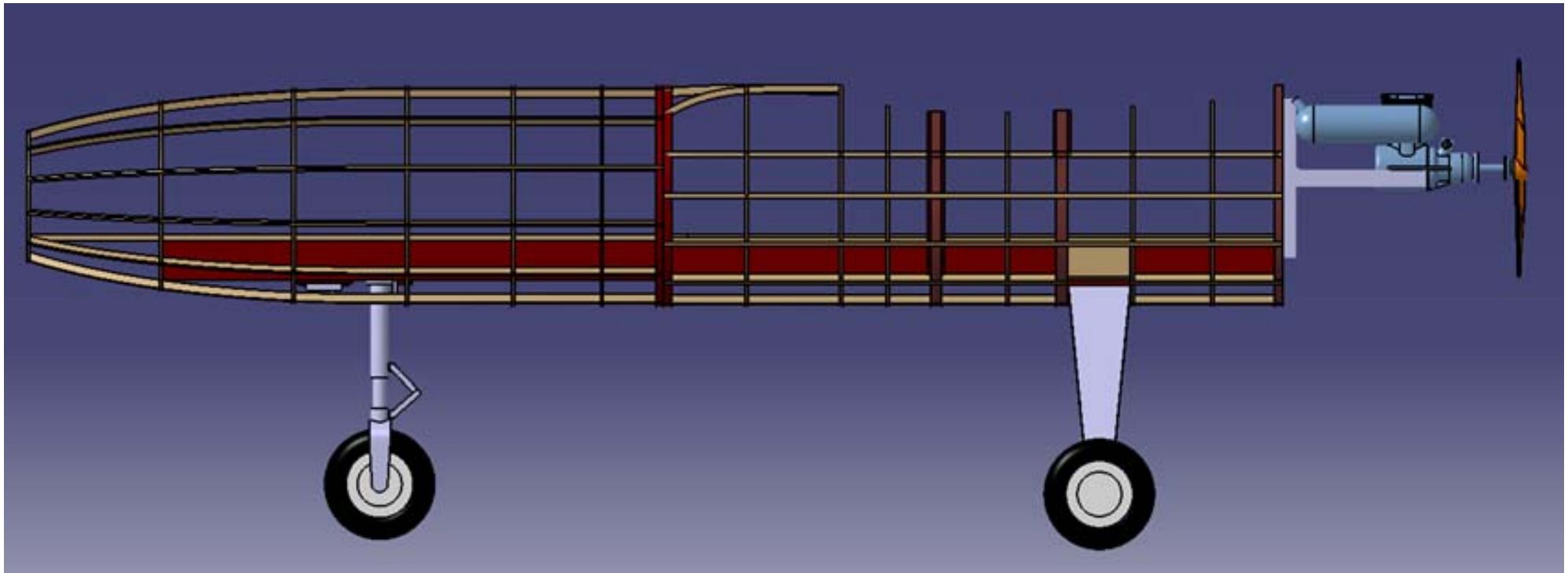



# Maderas en Céfiro - VII

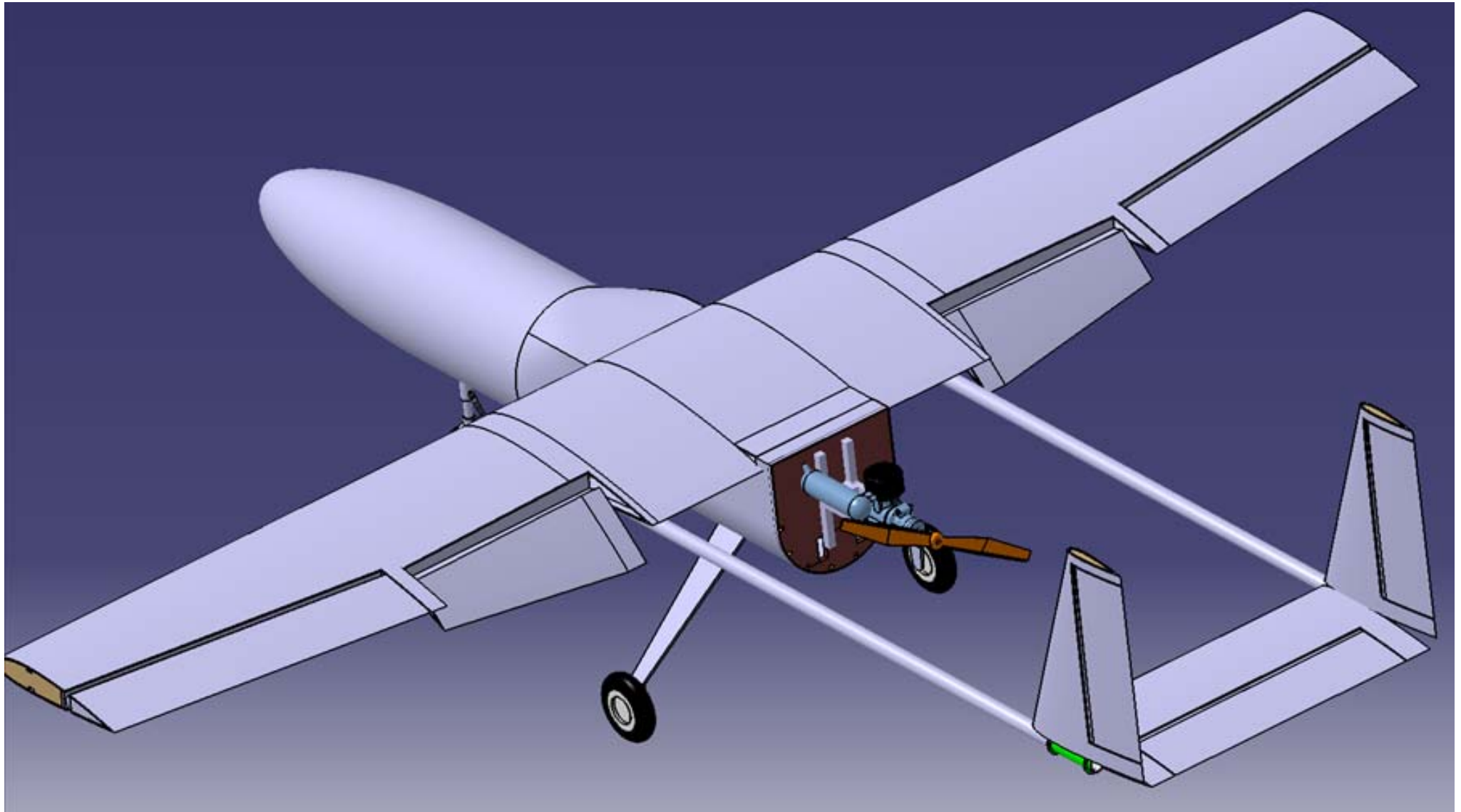



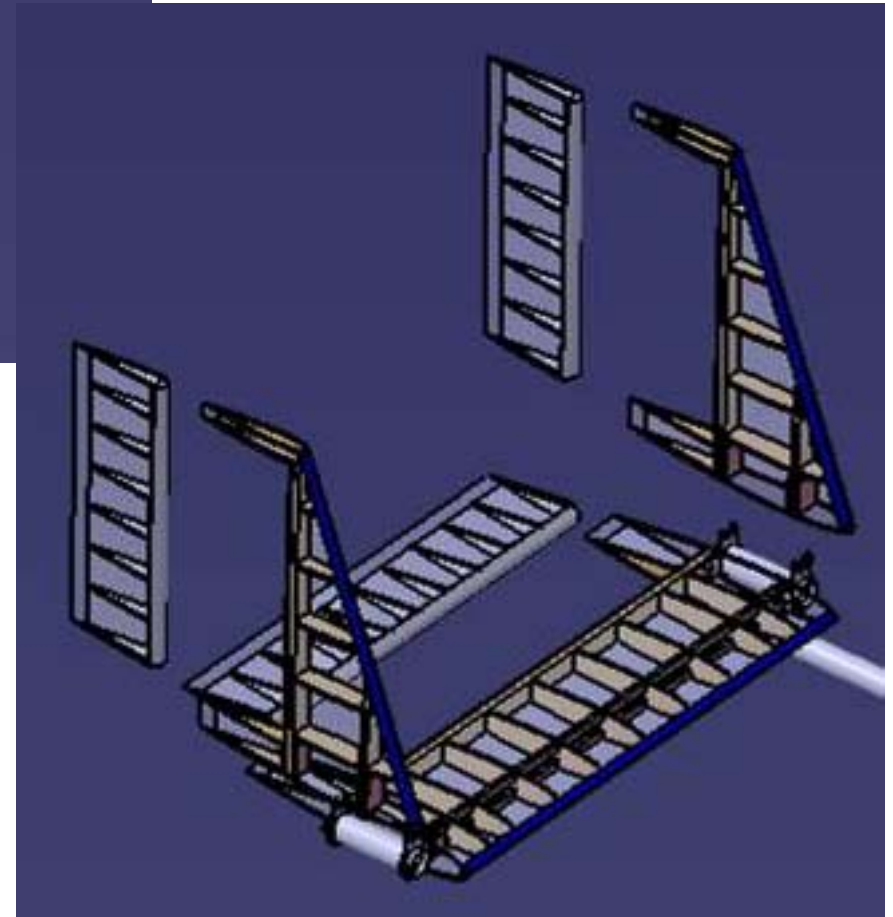
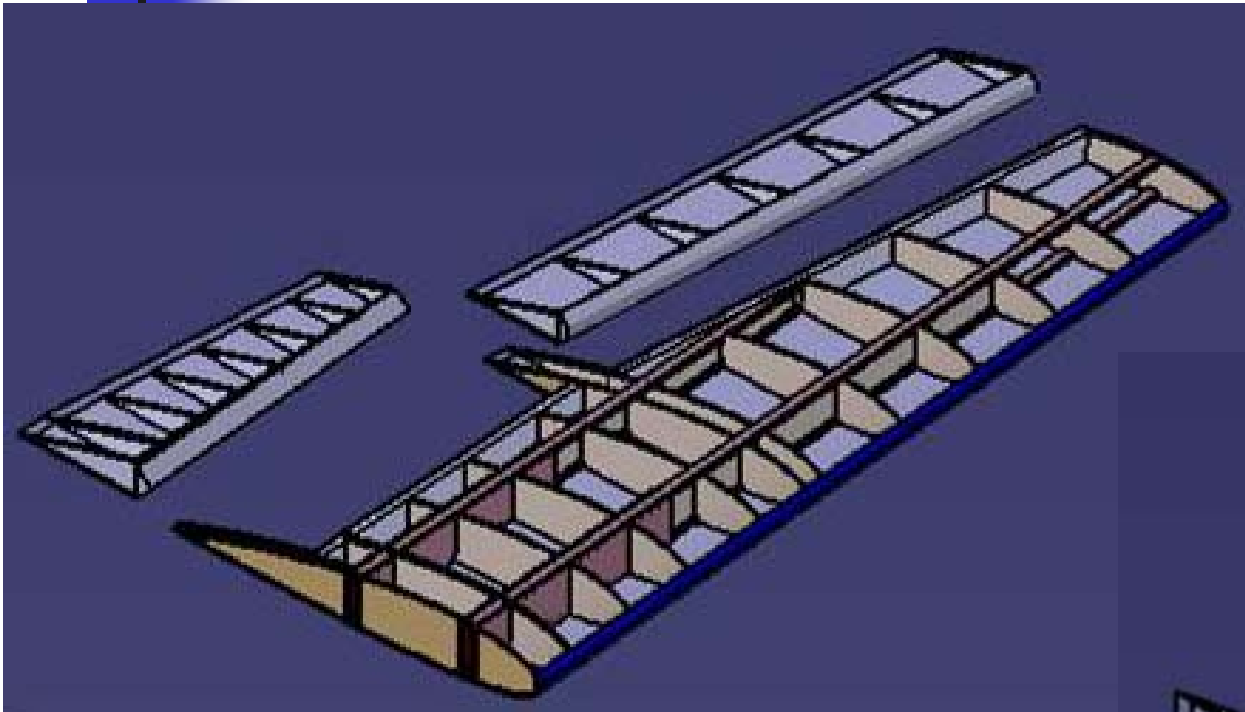





# Maderas en Céfiro - VIII











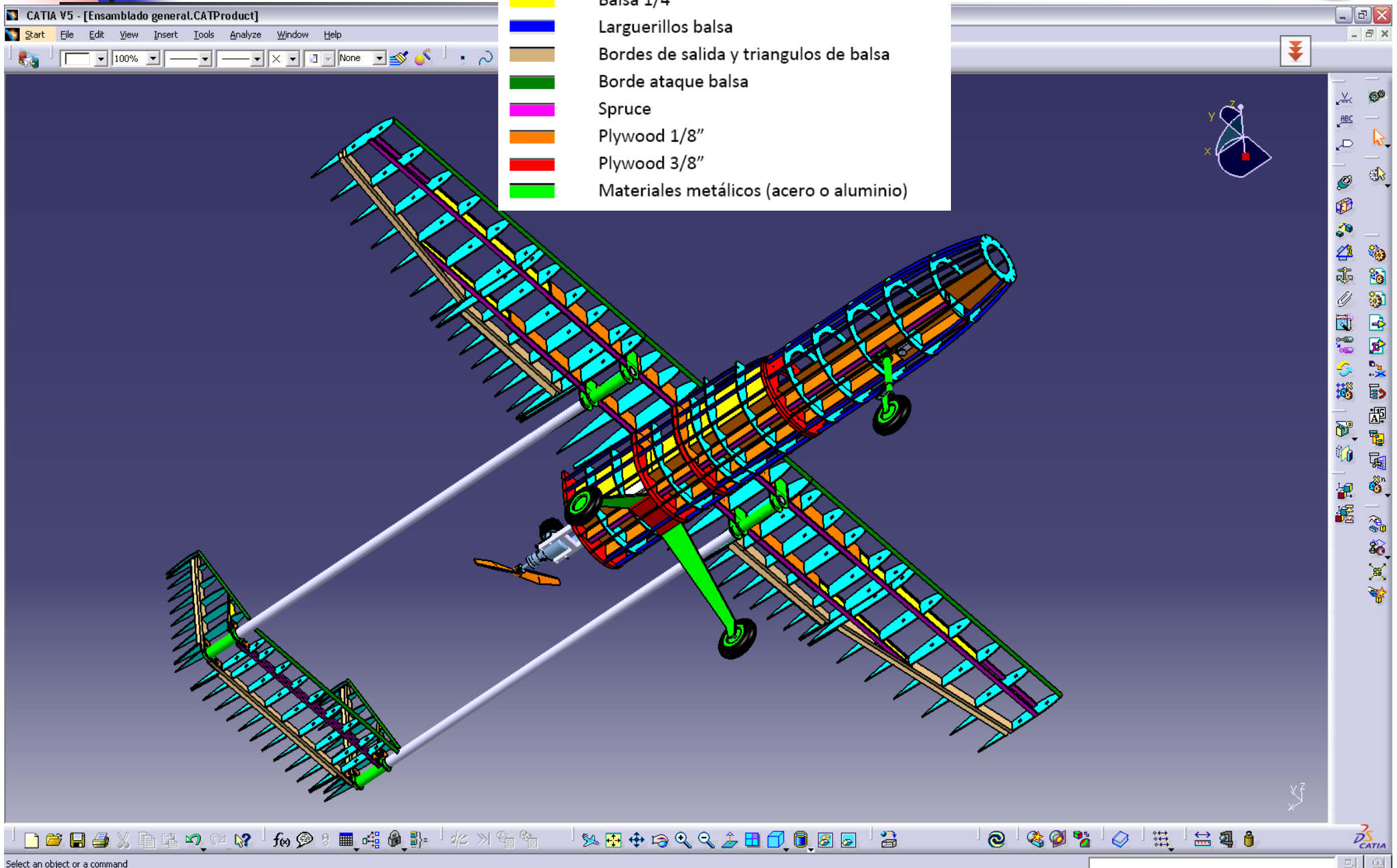



# Desglose por Zonas



-  Balsa 1/8"
-  Balsa 1/4"
-  Larguerillos balsa
-  Bordes de salida y triangulos de balsa
-  Borde ataque balsa
-  Spruce
-  Plywood 1/8"
-  Plywood 3/8"
-  Materiales metálicos (acero o aluminio)





-  Balsa 1/8"
-  Balsa 1/4"
-  Larguerillos balsa
-  Bordes de salida y triangulos de balsa
-  Borde ataque balsa
-  Spruce
-  Plywood 1/8"
-  Plywood 3/8"
-  Materiales metálicos (acero o aluminio)

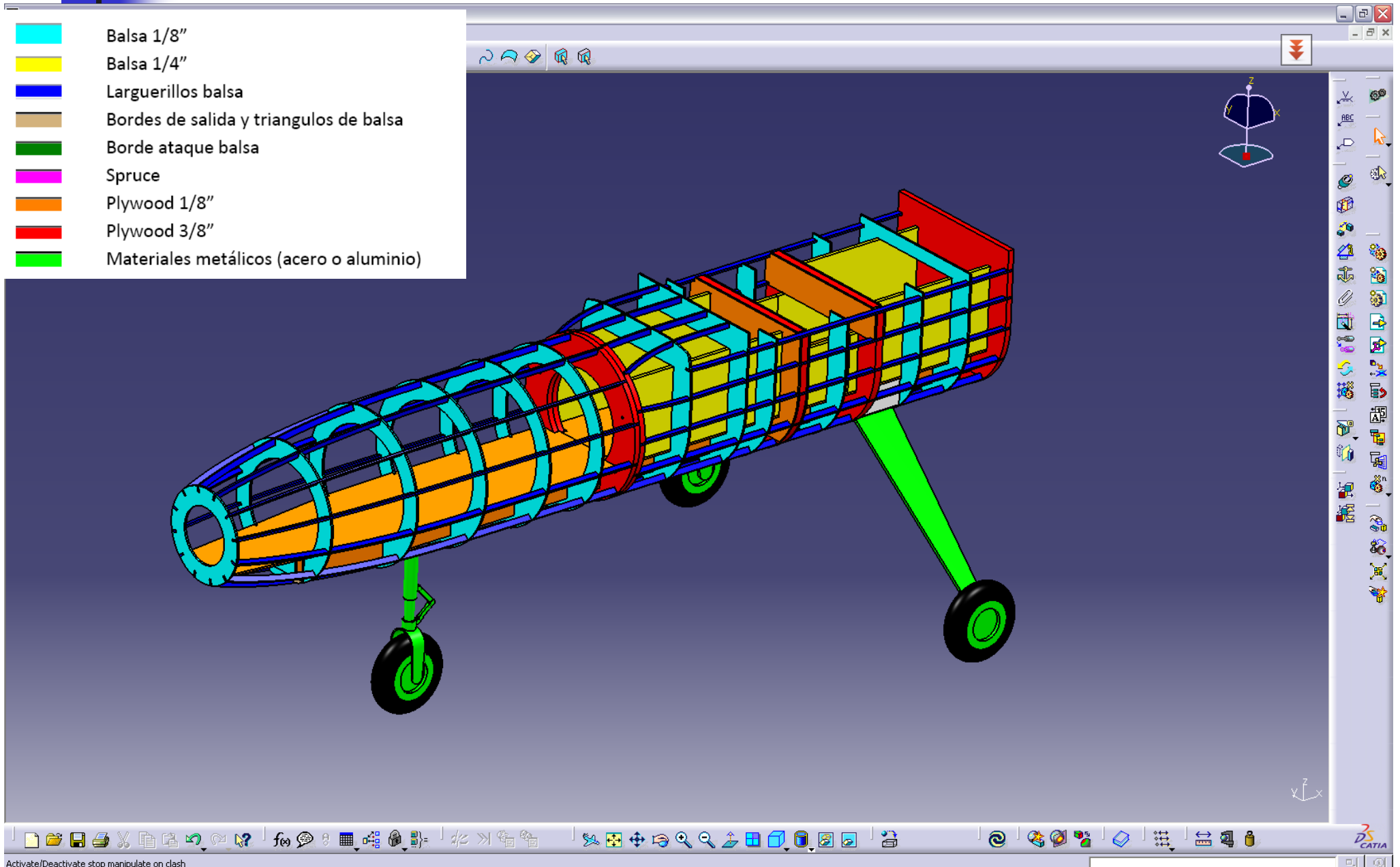

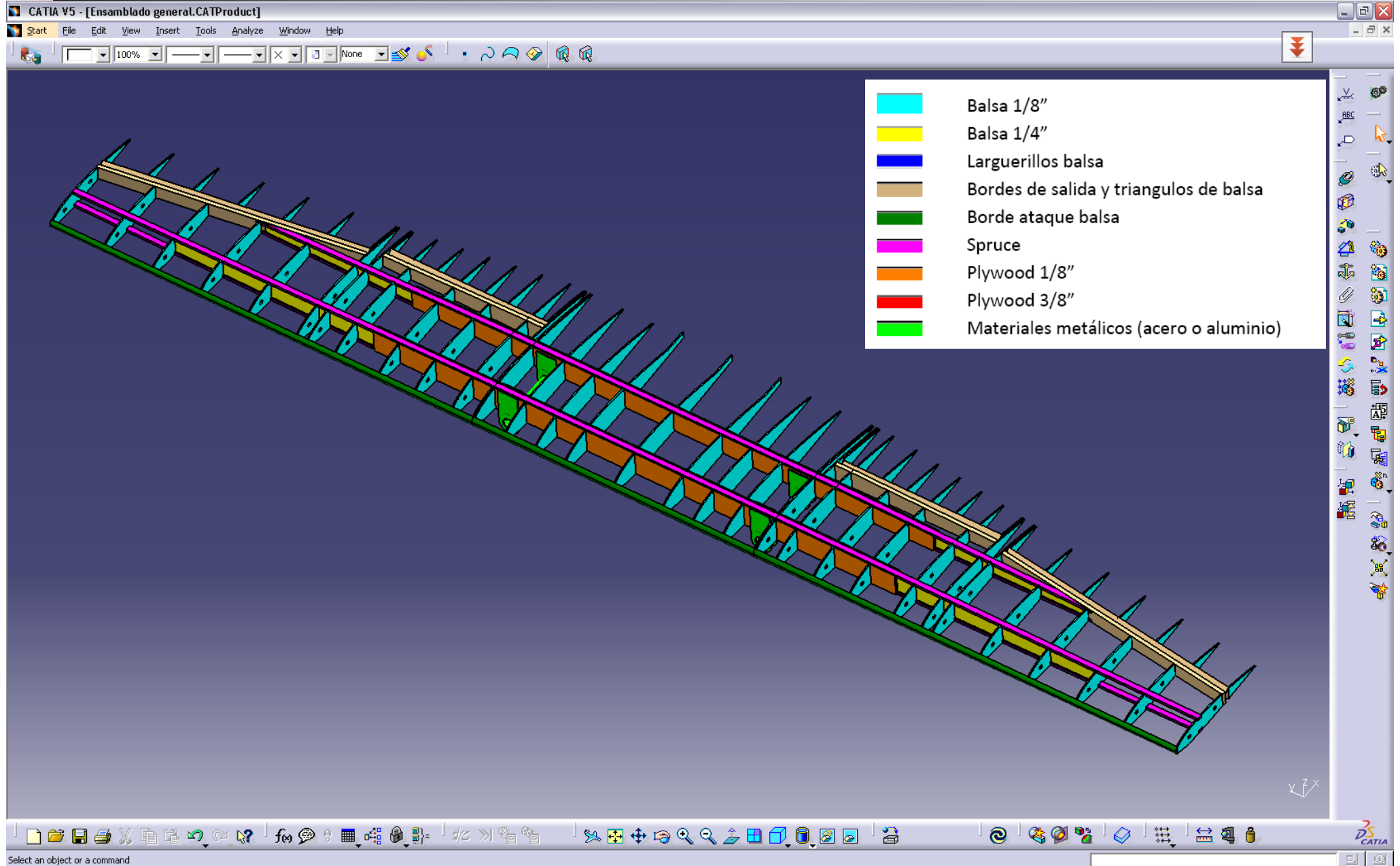

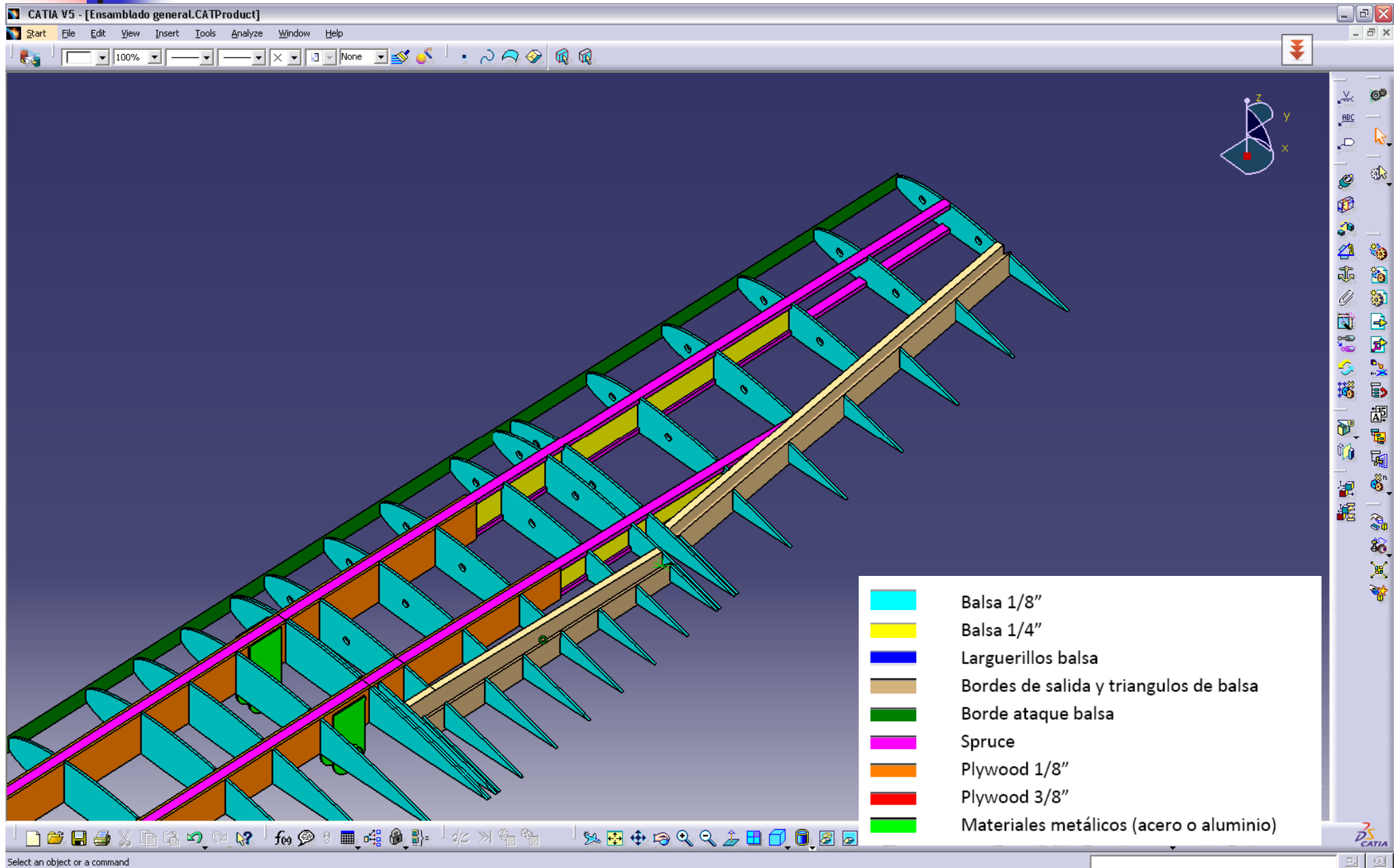

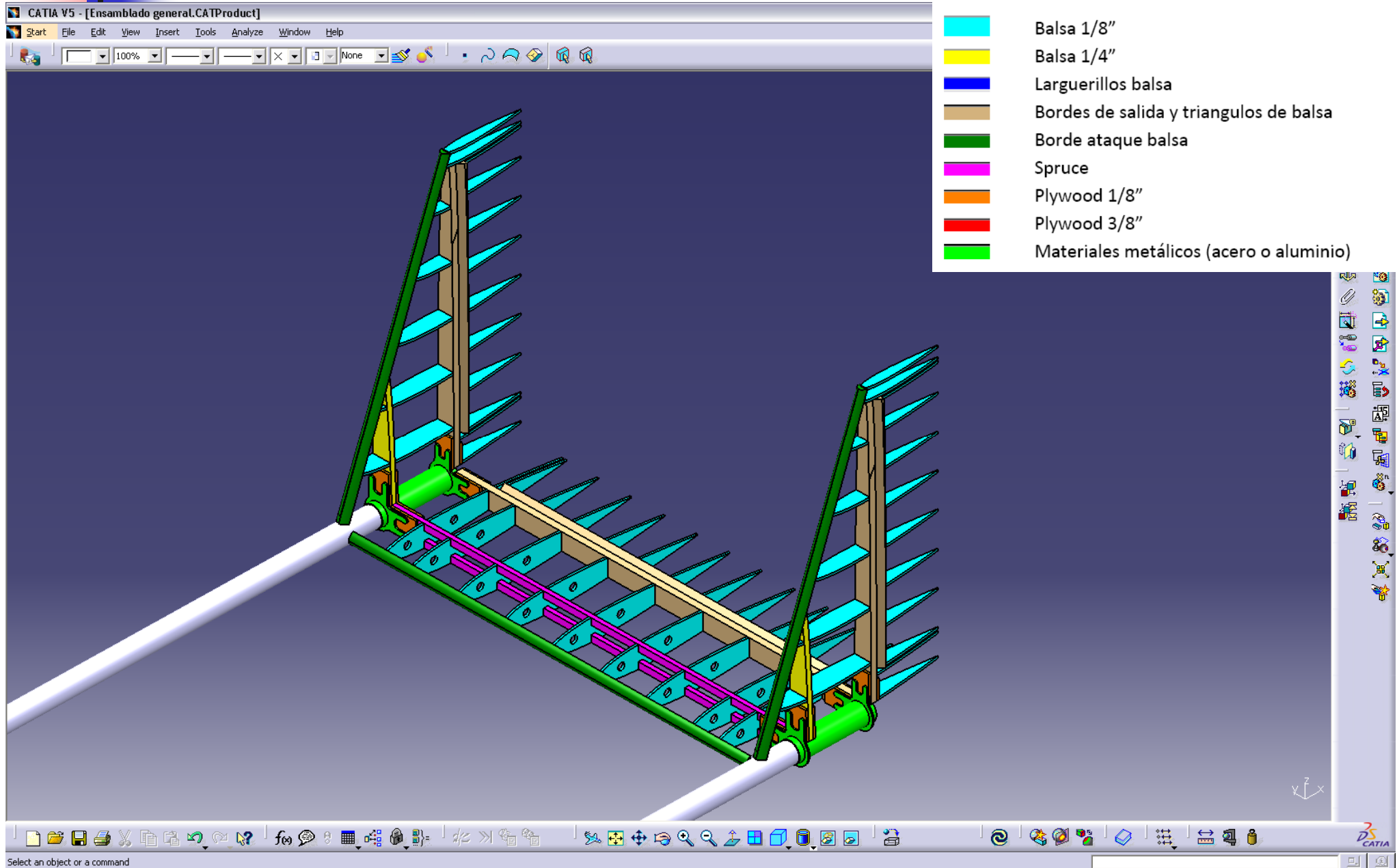





CATIA V5 - [Ensamblado general.CATProduct]

Start File Edit View Insert Tools Analyze Window Help

- Balsa 1/8"
- Balsa 1/4"
- Larguerillos balsa
- Bordes de salida y triangulos de balsa
- Borde ataque balsa
- Spruce
- Plywood 1/8"
- Plywood 3/8"
- Materiales metálicos (acero o aluminio)

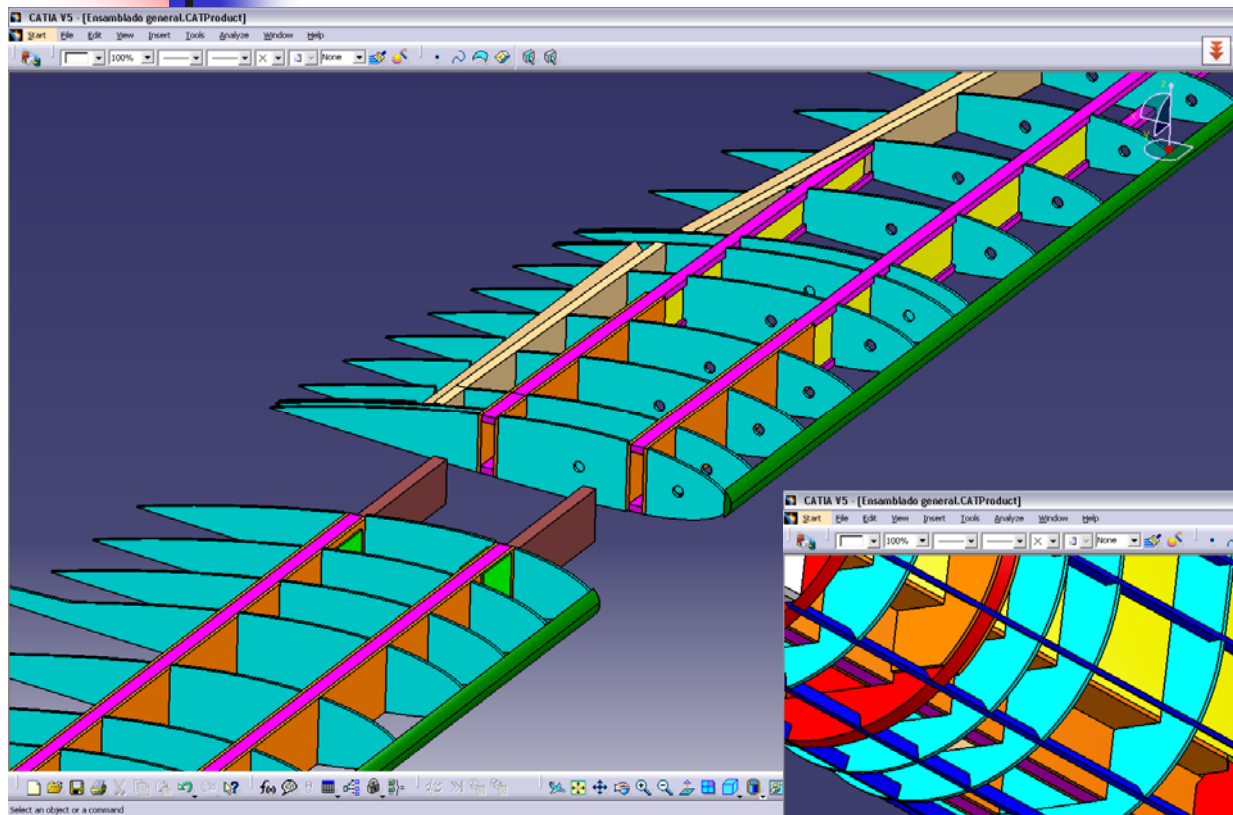

- Balsa 1/8"
- Balsa 1/4"
- Larguerillos balsa
- Bordes de salida y triangulos de balsa
- Borde ataque balsa
- Spruce
- Plywood 1/8"
- Plywood 3/8"
- Materiales metálicos (acero o aluminio)

